



GoBOX 400 | SLIDE OUT

ASSEMBLY GUIDE

GoBOX 400 | SLIDE OUT



* Optional bike rack

TABLE OF CONTENTS |

WARNINGS	3
MAINTENANCE	4
REQUIRED MATERIALS NOT INCLUDED	5
ASSEMBLY	11
BIKE RACK ASSEMBLY (OPTION)	33

SAFETY WARNINGS

****ATLAS RC disclaims all liability for injuries related to the installation, maintenance, or use of an ATLAS RC accessory. ****

- The initial assembly of a GoBox-400 may take several hours.
- Always wear cut-resistant gloves and safety glasses.
- It is recommended to have 2 people to lift panels at certain times.
- If you have any doubts during assembly, stop the work and contact your retailer.

TECHNICAL WARNINGS

****For all bolts assembled with nylon lock nuts, it is mandatory to apply the anti-seize compound provided with your hardware to ensure that the bolt/nut assembly does not seize. ****

****It is important that the square shoulder of the carriage bolts be fully engaged in the square holes before tightening.****

- All bolts and nuts must be tightened by hand, using ratchets, Allen keys, and a torque wrench, according to the torque specifications indicated in this guide. .

REQUIRED TORQUE ACCORDING TO BOLT DIAMETER

- 5/16" = 24Nm
 - #10 = 3Nm
 - 1/4" = 12Nm
 - 3/8" = 30 Nm
-
- Nylon lock nuts, also called Nylock nuts, are used in the assembly of ATLAS accessories. Repeated tightening and loosening of this type of nut is not recommended. It is therefore very important to follow the tightening steps specified in this manual.

GENERAL WARNINGS

- It is your responsibility to confirm that your vehicle hitch has the capacity to support a GoBox-400 and its cargo.
- Maximum total payload: 200 lb (90 kg)
- Maximum of 55 lb per bike, 110 lb maximum for bikes.
- The bike rack arms must be locked at all times during transport to ensure they remain secure.
- Limitation of Liability by ATLAS RC: ATLAS RC is not responsible for damages resulting from improper use, overloading, incorrect assembly, abuse, accidents, negligence, improper installation, theft, or unauthorized modifications.
- As the owner of an ATLAS RC accessory, it is your responsibility to review the company's Terms and Conditions on its website.
- Any modification or alteration to ATLAS RC accessories not approved by ATLAS RC may void the product warranty.
- The addition of components not approved by ATLAS RC may void the product warranty.

PRIVACY POLICY

The customer is responsible for reading the "Privacy Policy" page on the Atlas Roadcamp website:
<https://atlasroadcamp.com/politique-de-confidentialite>

MAINTENANCE

1. All torque specifications must be verified after the first 100 km and 500 km driven following installation of the bracket.

It is mandatory to follow the specified tightening torque according to bolt diameter.

REQUIRED TORQUE ACCORDING TO BOLT DIAMETER

- 5/16" = 24Nm
- #10 = 3Nm
- 1/4" = 12Nm
- 3/8" = 30 Nm

2. Check that all hardware remains properly tightened annually.

COMPONENTS INCLUDED IN THE BOX

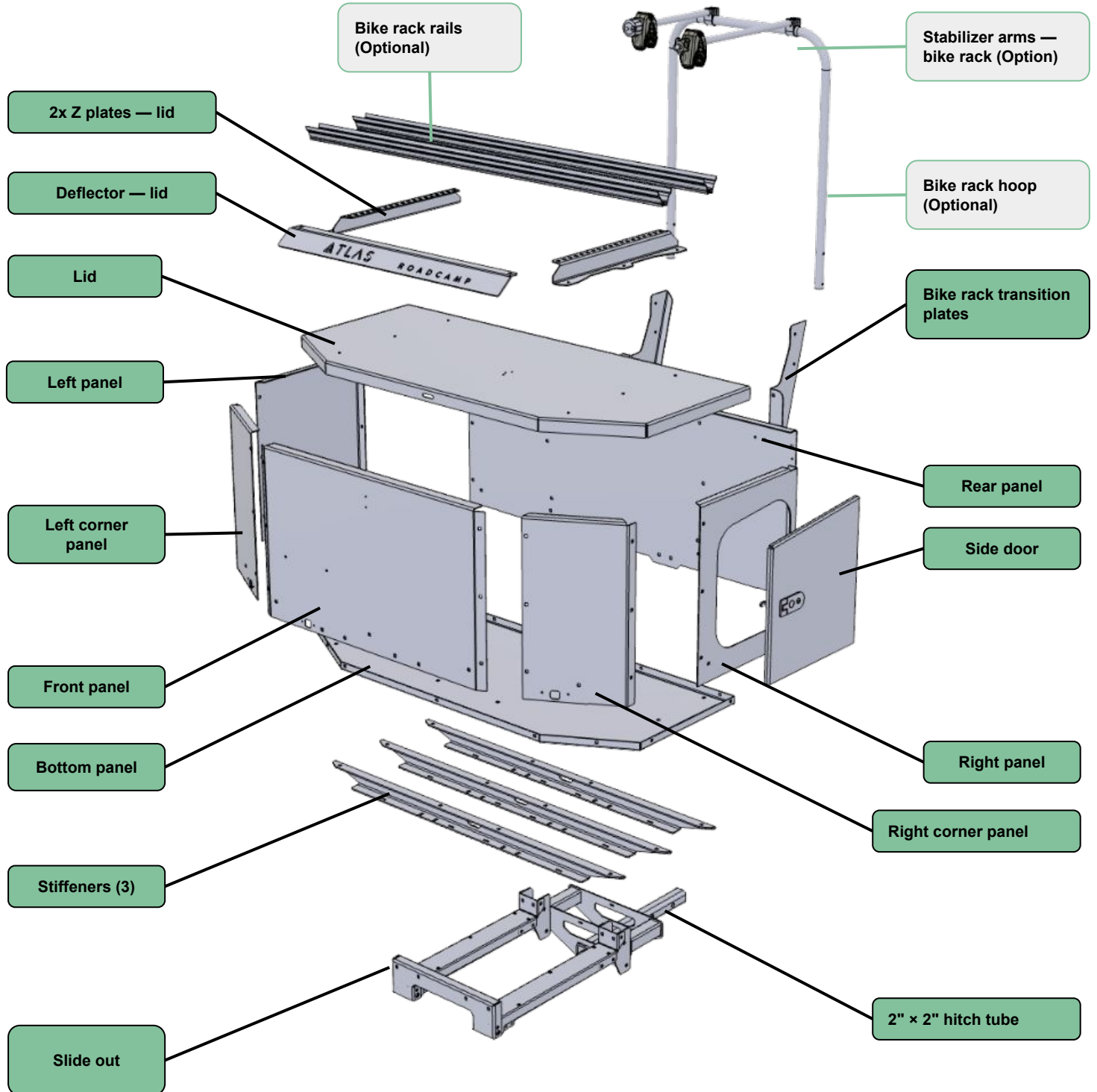

COMPONENTS INCLUDED IN THE BOX

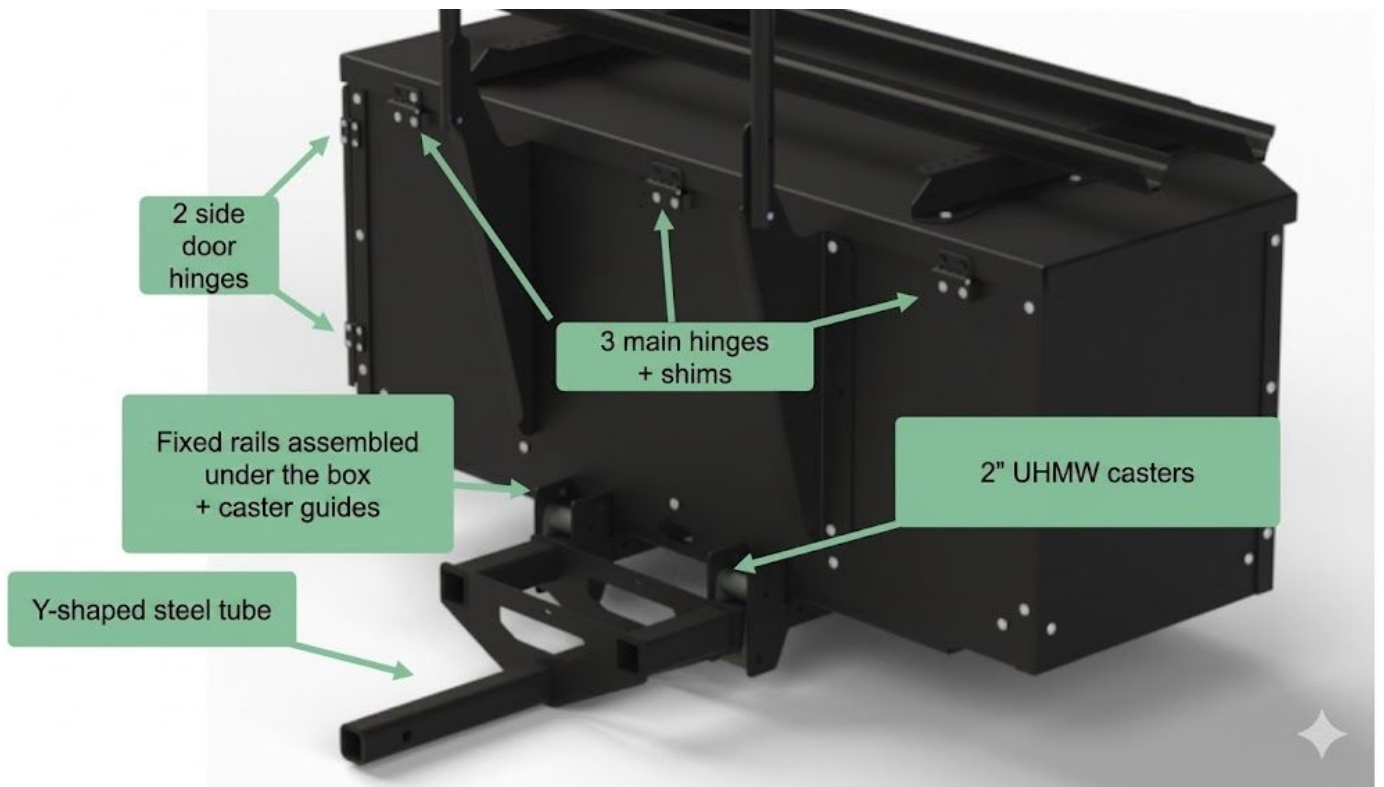
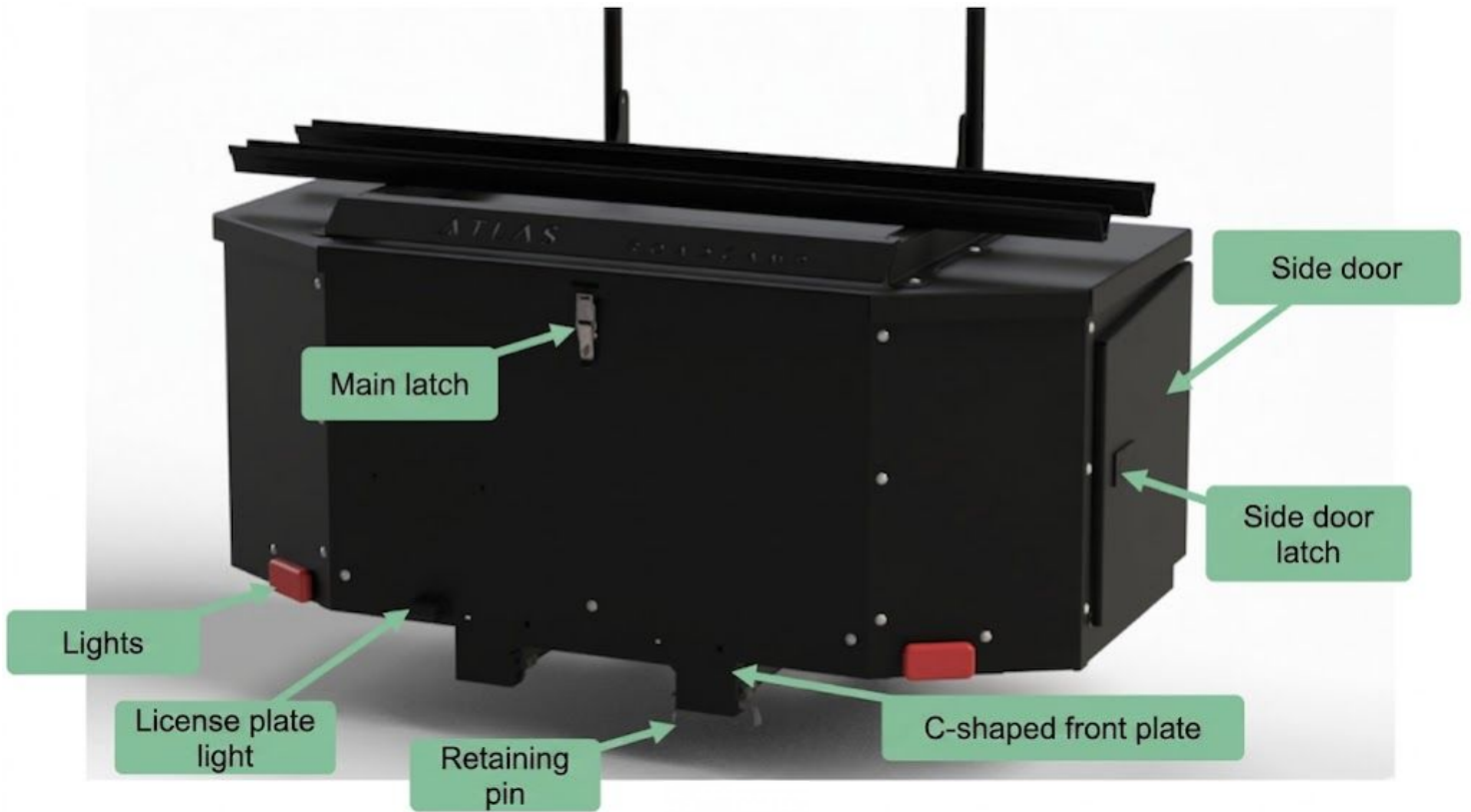

INCLUDED COMPONENTS

IN THE HARDWARE BOX



3x
Main hinges



3x
Hinge spacers



1x
Side door latch



2x
Side door hinges



1x
Gas spring



1x
Latch padlock
(Model may differ from photo)



1x
Set of 2 LED lights for signals
and license plate light



1x
Cable tie kit
(Tie Wrap)



1x
1/2 Hitch lock



1x
Hitch clamp
(anti-rattle, stabilization)











1x
Anti-seize

****IMPORTANT** :Apply anti-seize
cto the threads of all bolts before
installing the nuts**

HARDWARE INCLUDED BY BAG

SLIDE-OUT Bag				
				
4x Carriage bolts 5/16" X 1"	28x Carriage bolts 5/16" X 3/4"	40x Washer 5/16"	36x Nylon lock nuts 5/16"	6x THIN nylon lock nuts M10
				
4x Shoulder bolt M12XM10X 50mm	4x Shoulder bolt M12XM10X 80mm	4x UHMW roller, 2" wide	1x Safety rod	

Bag #1		
		
32x Carriage bolts 5/16" X 3/4"	32x Washer 5/16"	32x Nylon lock nuts 5/16"

Bag #2					
					
12x Carriage bolts 5/16" X 3/4"	18x Washer 5/16"	18x Nylon lock nuts 5/16"	6x Round head bolts 5/16" X 3/4"	6x Sealing washer 5/16"	6x Sealing washer 5/16" with plates

HARDWARE INCLUDE PAR Bag

Bag #3						
8x Countersunk head bolts #10 X 3/4"	8x Nylon lock nuts #10	8x Washer #10	6x Countersunk head bolts 1/4" X 5/8"	6x Countersunk head bolts 1/4" X 11/4"	12x Washer 1/4"	12x THIN nylon lock nuts 1/4"

Bag #4				
6x Round head bolts #10 X 5/8"	6x Socket head bolts #10" X 3/4"	12x Nylon lock nuts #10	12x Washers #10	6x Washers scellantes #10

Bag #5			
4x Hex bolts 5/16" X 1-3/4"	6x Hex bolts 5/16" X 3/4"	10x Nylon lock nuts 5/16"	16x Washers 5/16"

Bag #6		
2x Hex bolts 1/4" X 3/4"	7x Washer 1/4"	2x Nylon lock nuts 1/4"

REQUIRED TOOLS



Ratchet

- 9/16" socket
- 1/2" socket
- 7/16" socket
- 3/8" socket



Torque wrench



Hex key

- 1/8" Allen key



Clamps

1 INSTALL ALL SIDE PANELS.

1.1 Install the rear panel

- Align the bottom holes of the rear panel with the rear holes of the bottom panel of the box. (A)
- Insert the 5 bolts, at the bottom of the rear panel, from the outside of the box toward the inside.
- Install the Washer on the bolts from the inside.
- Install the Nylon lock nuts 5/16" on the bolts from the inside.
- Apply anti-seize to the bolt threads. (B)
- Tighten the nuts by hand only. Leave the nuts loose to make installation of the other panels easier. (C)

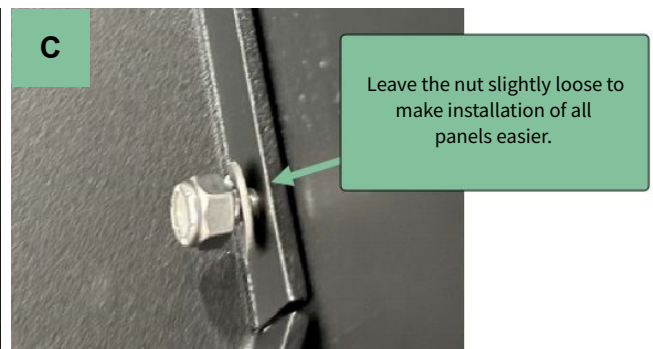
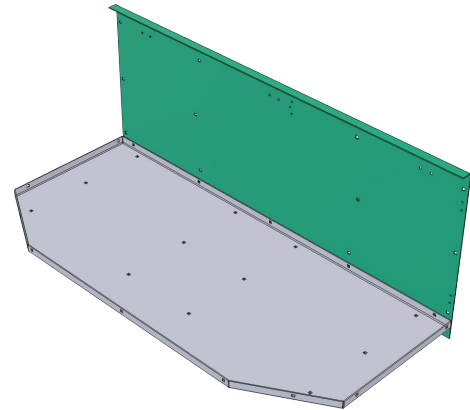

1 INSTALL ALL SIDE PANELS

1.2 Install the side panels.

- Align the panel holes with those on the bottom panel and also with those on the rear panel. (A)
- The panels must overlap the rear panel.
- Insert the 5 bolts per panel from the outside toward the inside.
- Install the Washer on the bolts from the inside.
- Apply anti-seize to the bolt threads.
- Tighten the nuts by hand only. Leave the nuts loose for now.

HARDWARE Bag #1



10x Carriage bolts 5/16"
X 3/4"



10x Washer 5/16"



10x Nylon lock nuts 5/16"

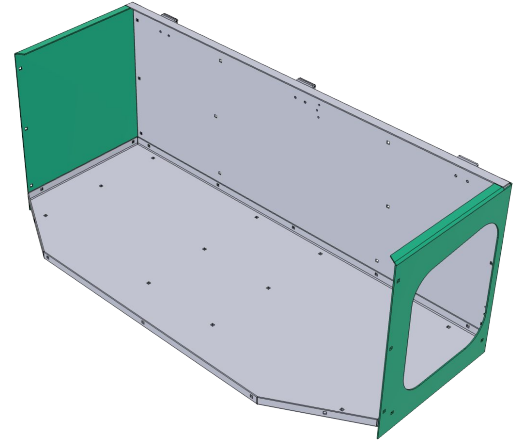

A



1 INSTALL ALL SIDE PANELS. .

1.3 Install the right and left corner panels.

- Align the holes of the corner panels with those on the bottom panel and also with those on the right panel. (A)
- The corner panel must overlap the right panel.
- Insert the 4 bolts per panel from the outside toward the inside.
- Install the Washer on the bolts from the inside.
- Apply anti-seize to the bolt threads.
- Tighten the nuts by hand only. Leave the nuts loose for now.

HARDWARE Bag #1



Carriage bolts 5/16" X 3/4"



Washer 5/16"



Nylon lock nuts 5/16"

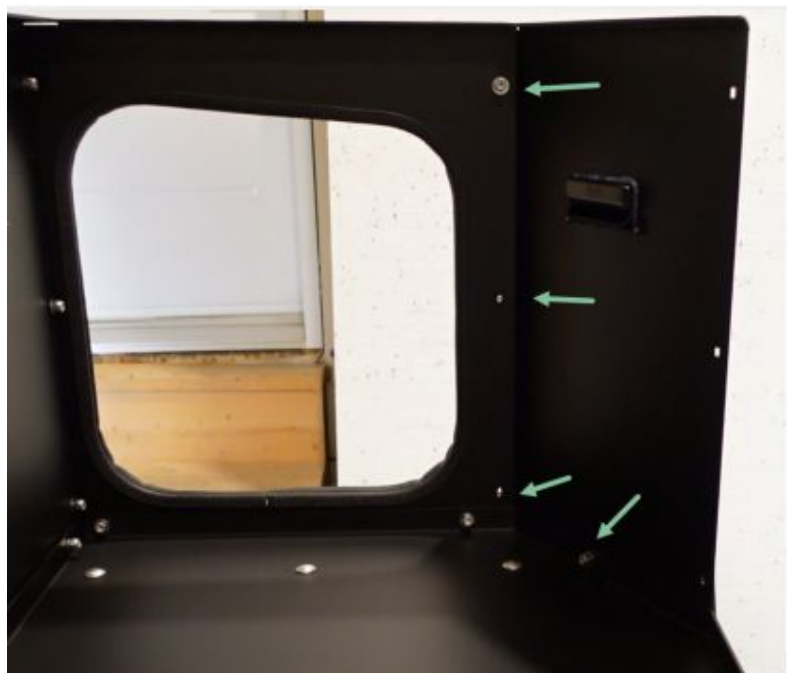
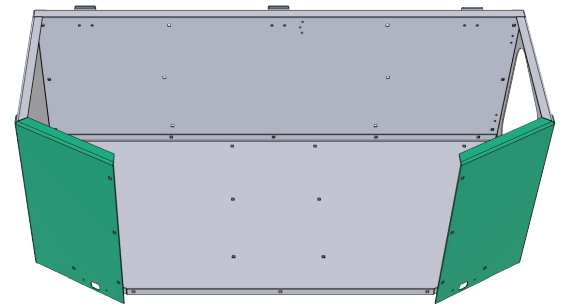

1 INSTALL ALL SIDE PANELS. .

1.4 Install the front panel, with pre-installed main latch.

- Align the holes of the front panel with those on the bottom panel and also with those on the 2 handle panels. (A)
- The front panel must overlap the 2 handle panels.
- Insert the 9 bolts from the outside toward the inside.
- Install the Washer on the bolts from the inside.
- Apply anti-seize to the bolt threads.
- Tighten the nuts by hand only. Leave the nuts loose for now.

HARDWARE Bag #1



Carriage bolts 5/16" X 3/4"



Washer 5/16"



Nylon lock nuts 5/16"

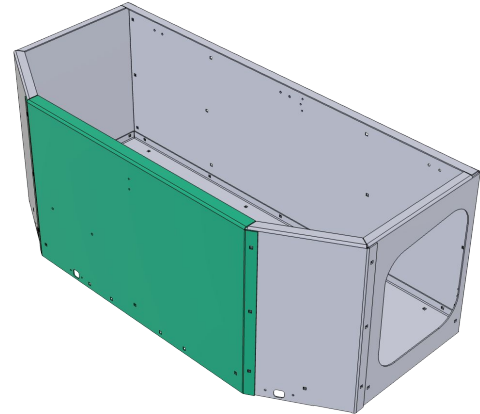

1 INSTALL ALL SIDE PANELS. .

HARDWARE Bag #1



Carriage bolts 5/16" X 3/4"



Washer 5/16"



Nylon lock nuts 5/16"

1.5 Tighten the 32 carriage bolts 5/16" × 3/4".

- It is important that the square shoulder of the bolt head be properly inserted into the square hole before tightening everything.
- Make sure to tighten to the required torque. (See Page 3)

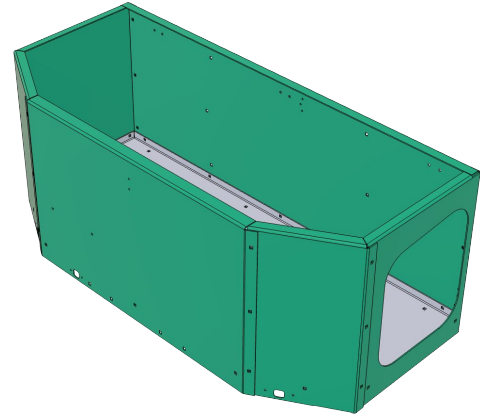

2 INSTALL THE LATCH ON THE SIDE DOOR

- Unscrew the hex head bolt with the U-shaped bracket and remove them. (A)
- Insert the latch into the side door panel, making sure the door panel is oriented correctly. (B)
- Place 2 Washer 1/4" under the U-plate (C) and 1 washer 1/4" under the bolt head. (D)
- Tighten the bolt to complete installation of the secondary latch.
- Use the adjustment nut to adjust the door latch if needed. (E)

HARDWARE: Bag #6



3x Washer 1/4"

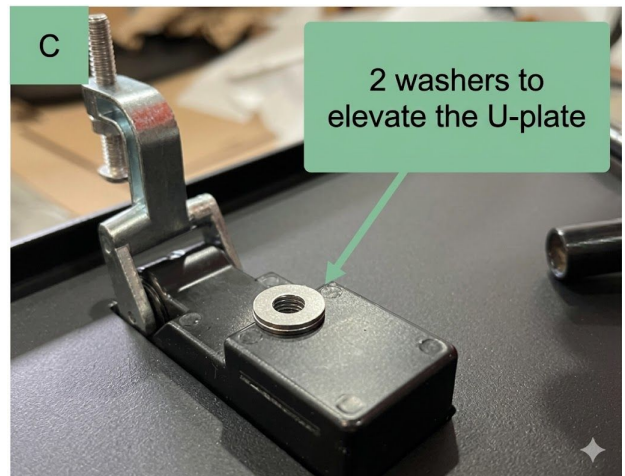
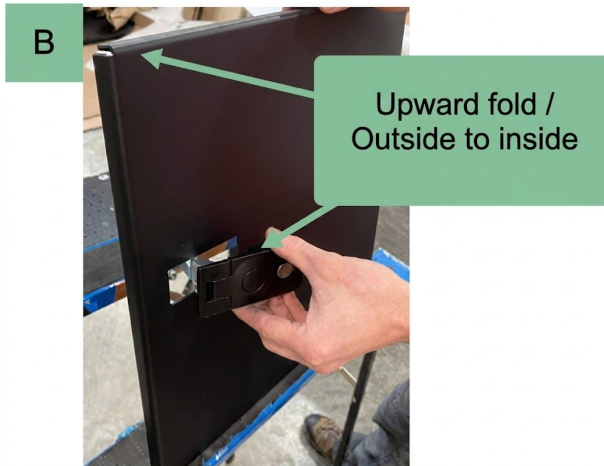
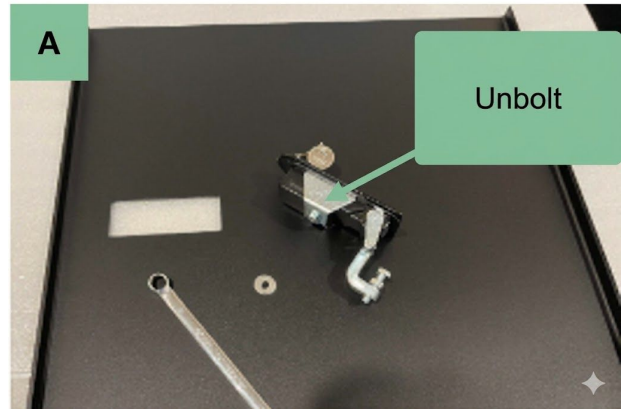
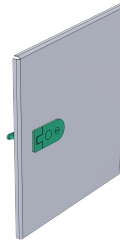

3 INSTALL THE 2 SIDE DOOR HINGES.

****Follow the specified torque of 3 Nm. ****

****DO NOT OVERTIGHTEN. The bolt head should be slightly recessed into the hinge.****

- Insert the 2 bolts per hinge.
- Install the hinges with the bolts on the side door.
- Install the Washer on the bolts from the inside.
- Apply anti-seize to the bolt threads.
- Tighten the nuts.

HARDWARE: Bag #3



2x Side door hinges



4x Countersunk head bolts #10 X 3/4

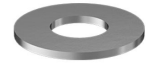

4x Washer #10



4x Nylon lock nuts #10

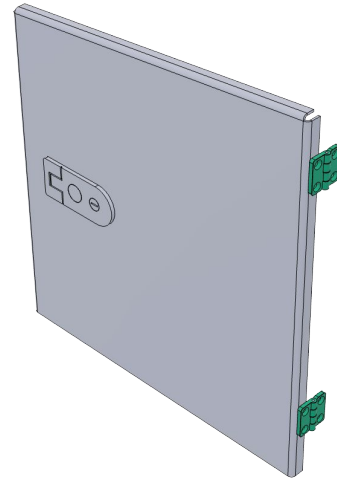

A



B



C



4 INSTALL THE SIDE DOOR ONTO THE BOX

****Follow the specified torque of 3 Nm.****

****DO NOT OVERTIGHTEN. The bolt head should be slightly recessed into the hinge.****

- Insert the 2 bolts per hinge. (A)
- Install the hinges with the bolts on the box panel. (B)
- Install the Washer on the bolts from the inside. (C)
- Apply anti-seize to the bolt threads.
- Tighten the nuts.

HARDWARE: Bag #3



4x Countersunk head bolts #10 X 3/4

4x Washer #10

4x Nylon lock nuts #10

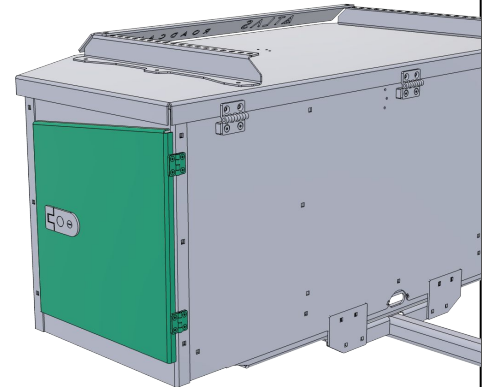

5 ASSEMBLE THE DEFLECTOR ONTO THE Z BARS

- Gather the deflector and the 2 Z bars.
- Make sure the deflector is above the bars. (A)
- Assemble them upside down to make tightening easier. (B)
- Insert the 2 bolts from the outside toward the inside.
- Install the Washer on the bolts from the inside.
- Apply anti-seize to the bolt threads.
- Tighten the nuts by hand only. Do not fully tighten yet, to allow alignment with the holes on the lid

HARDWARE: Bag #2

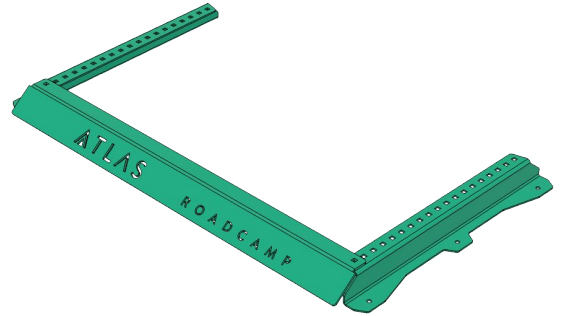

6 INSTALL THE DEFLECTOR/Z BAR ASSEMBLY ONTO THE LID

- Place the assembly from the previous step onto the lid.
- Align the holes. (A)
- Install the sealing Washer under the bolt heads onto the bolts. (B)
- Place the white sealing Washer between the Z plates and the lid.
- Insert the 6 bolts from the outside toward the inside of the box, passing through the white sealing washer.
- Apply anti-seize to the bolt threads.
- Tighten the nuts to the specified torque.

HARDWARE: Bag #2



6x Round head bolts
5/16" x 3/4"

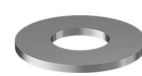

2x Washer 5/16"



2x Nylon lock nuts 5/16"



6x Sealing washer 5/16"





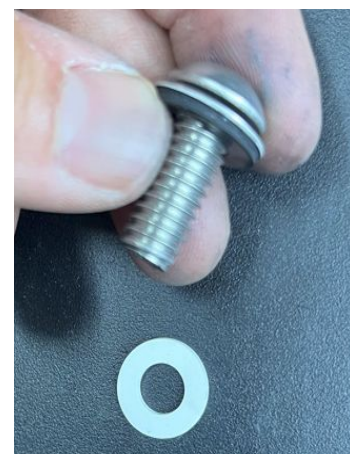
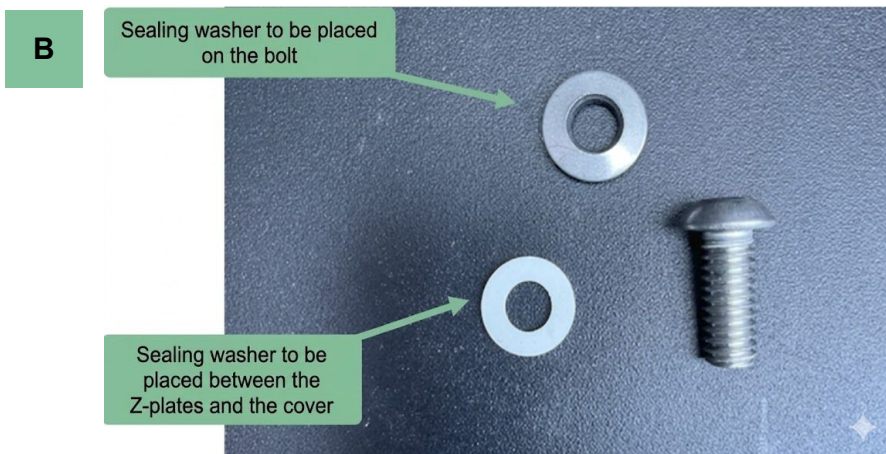
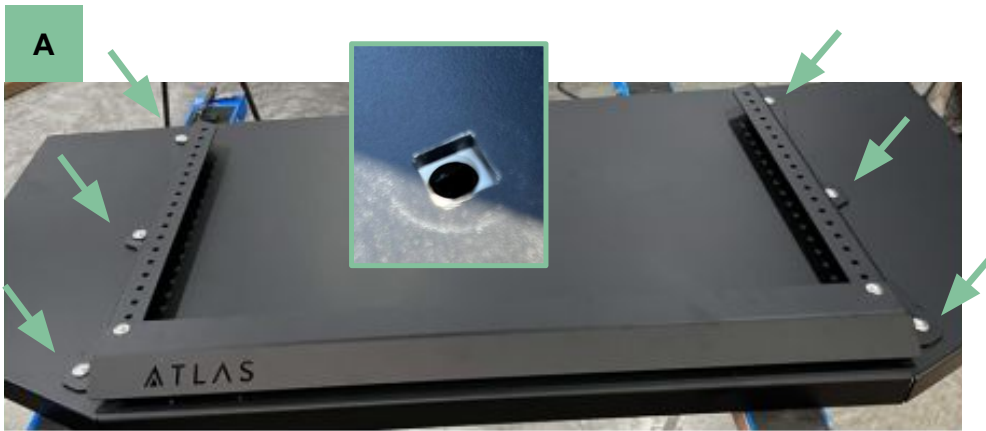
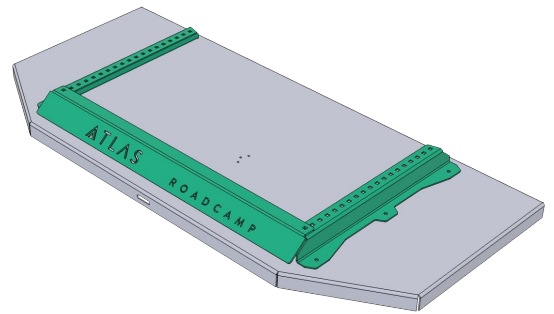

6x Sealing washer 5/16" between the plates (white)



7 ASSEMBLE THE HINGES ONTO THE LID

**** Be careful not to overtighten.****

- Insert the 2 bolts per hinge. (A)
- Install the hinges with the bolts onto the lid. (B)
- Install the Washer on the bolts from the inside.
- Apply anti-seize to the bolt threads.
- Tighten the nuts to the specified torque.

HARDWARE: Bag #4			
			
3x Main hinges	6x Countersunk head bolts 1/4" x 5/8"	6x Washer 1/4"	6x THIN Nylon lock nuts 1/4"

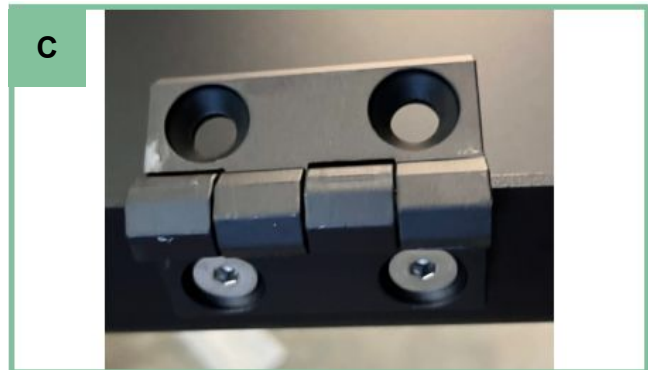
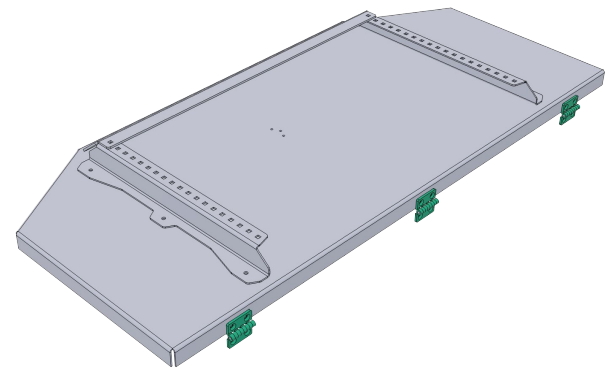

8 INSTALL THE GAS SPRING (REAR PANEL SIDE)

- Install the sealing Washer onto the bolts. (A)
- Insert the 3 bolts from the outside toward the inside while passing through the holes in the gas spring plate. (B)
- Apply anti-seize to the bolt threads.
- Tighten the nuts to the specified torque.
- Let the gas spring rest downward for now. (C)

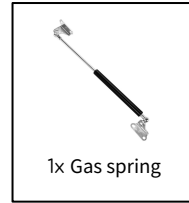

HARDWARE: Bag #4

3x Round head bolts #10 x 5/8"	3x Washer #10
3x Sealing washer #10	3x Nylon lock nuts #10

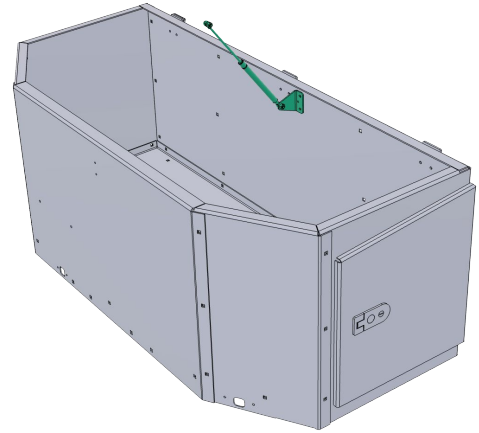

9 INSTALL THE LID ONTO THE BOX



3 spacers, 1/2" thick,
for main hinges
(box side)

HARDWARE: Bag #3



6x Countersunk
head bolts 1/4" X
1-1/4

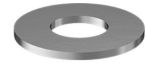

6x Washer 1/4"



6x Nylon lock
nuts 1/4"

****Caution: this step must be done by 2 people****

- Place the lid onto the box.
- Use this image to identify the 3 hinges.

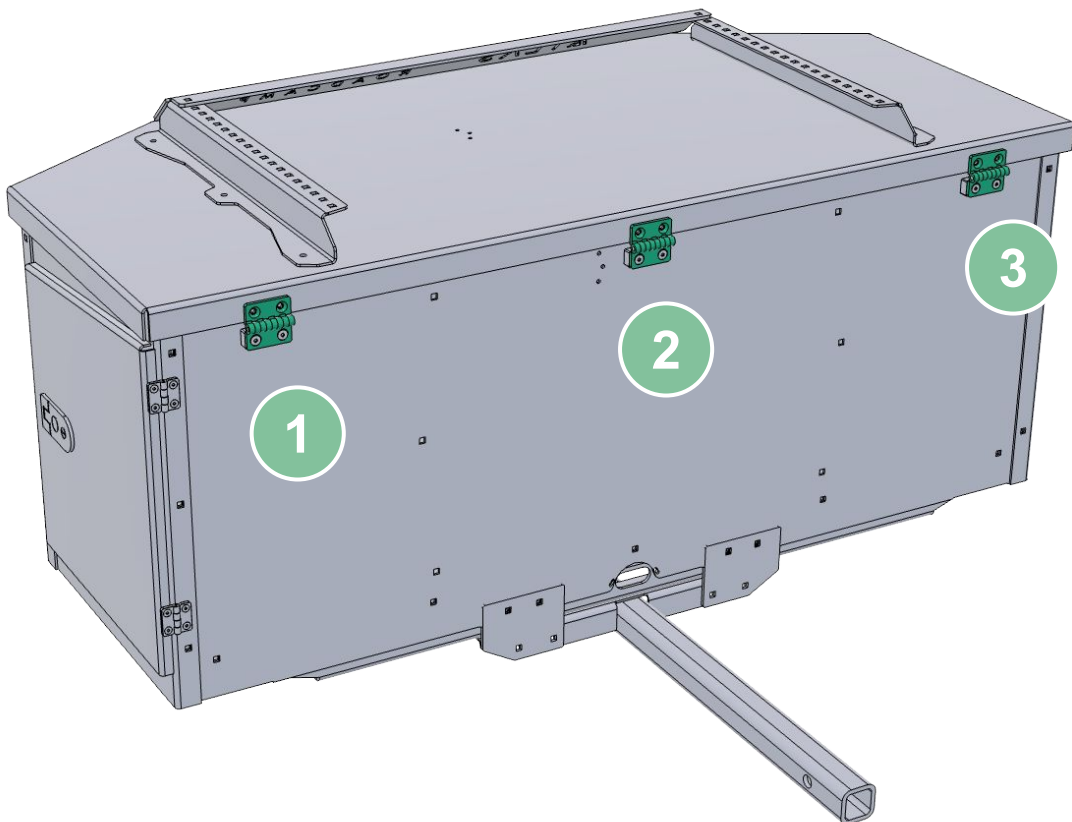

10 INSTALL THE LID ONTO THE BOX



3 spacers, 1/2" thick, for main hinges (box side)

HARDWARE: Bag #3



6x Countersunk head bolts 1/4" X 1-1/4"



6x Washer 1/4"



6x Nylon lock nuts 1/4"

10.1 Install hinge #1

- Insert a spacer between hinge #1 (A, B) and the box.
- Insert the 2 bolts 1/4" X 1-1/4" through the hinge, the spacer, and the box.
- Through the open side panel, install 2 Washer and nuts.
- Apply anti-seize.
- Tighten the 2 nuts to a torque of 7 Nm.



10 INSTALL THE LID ONTO THE BOX



3 spacers, 1/2" thick, for main hinges (box side)

HARDWARE: Bag #3



6x Countersunk head bolts 1/4" X 1-1/4



6x Washer 1/4"



6x Nylon lock nuts 1/4"

10.2 Install hinge #3

- Lift the lid and hold it open using the hardware box from your packaging.
- Repeat the same steps as for hinge #1.



10.3 Install hinge #2

- Repeat the same steps as for hinge #1.

11 INSTALL THE GAS SPRING (LID SIDE)

- Install the sealing Washer onto the bolts. (A)
- Insert the 3 bolts from the outside toward the inside while passing through the holes in the gas spring plate. (B)
- Install the Washer on the bolts from the inside.
- Apply anti-seize to the bolt threads.
- Tighten the nuts to the specified torque.



HARDWARE: Bag #4

	
3x Round head bolts #10 x 5/8"	3x Washer #10
	
3x Sealing washer #10	3x Nylon lock nuts #10

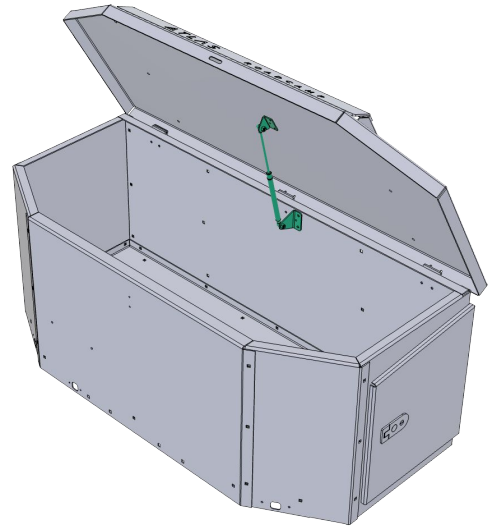

12 COMPLETE THIS STEP ONLY IF YOU DO NOT HAVE A BIKE RACK

****If you have a bike rack, skip this step.****

- Install one washer onto each bolt.
- Insert the 6 bolts from the outside toward the inside.
- Install the Washer on the bolts from the inside.
- Apply anti-seize to the bolt threads.
- Tighten the nuts to the specified torque of 24 Nm.

HARDWARE: Bag #5



6x Hex bolts 5/16" x 3/4"



12x Washer 5/16"



6x Nylon lock nuts 5/16"

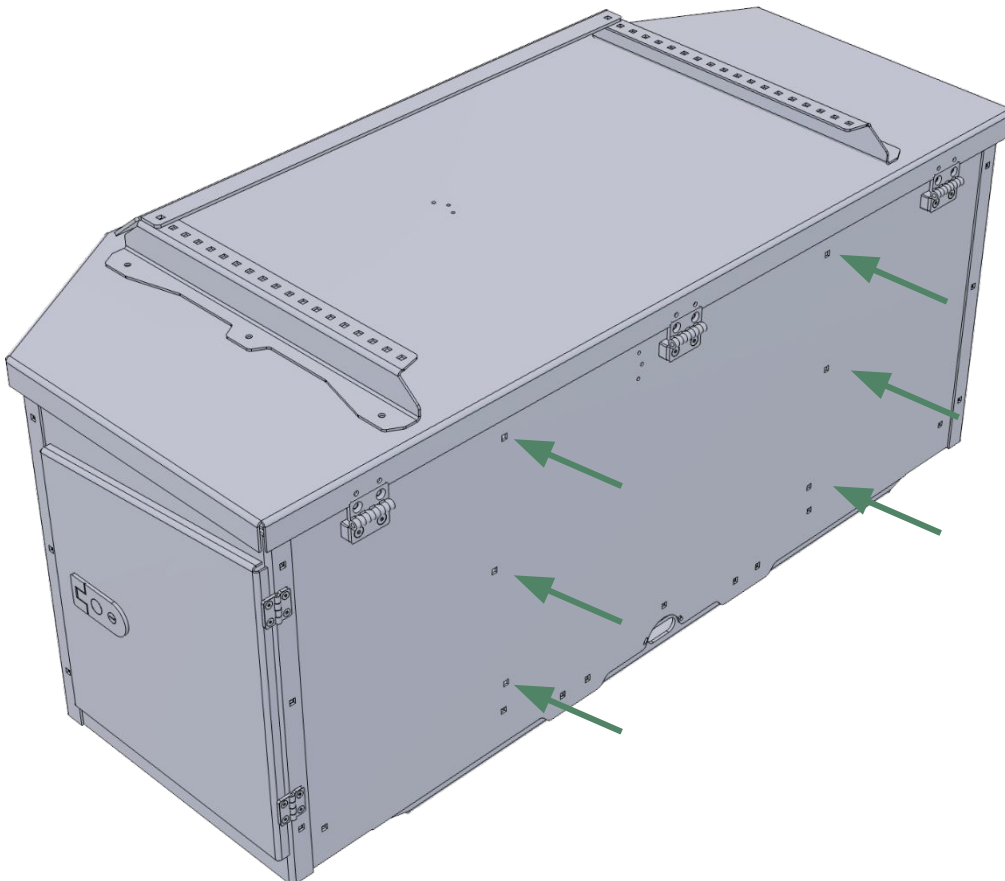

13 INSTALL THE LIGHTS AND ROUTE THE 4-WIRE HARNESS ABOVE THE TUBE THROUGH THE PROVIDED HOLES

13.1 Remove the red lenses from the lights. They are clipped on.



13.2
-Insert the 6" light wires into the holes of the handle panels.

- Insert the socket head bolts into the designated holes in the light plates and through the box.



13.3
- Apply anti-seize to the bolt threads.
- Tighten the nuts.
- Reinstall the red lenses.

HARDWARE: Bag #4



6x Socket head bolts #10" X 3/4"



6x Nylon lock nuts #10



6x Washer #10

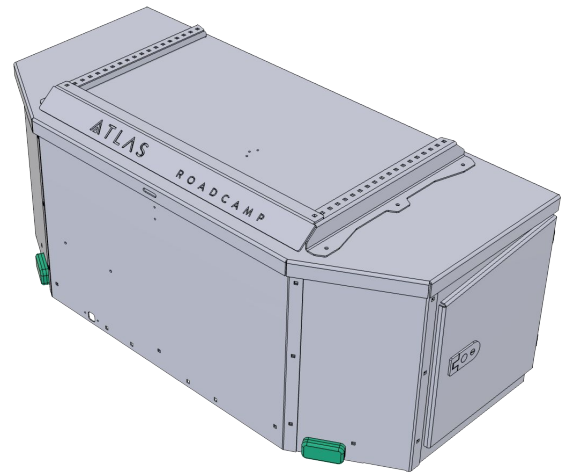

13.4 Install the license plate light with the black plastic cover oriented upward.



14 CONNECT AND SECURE THE WIRES

Connect the electrical wiring for the lights, route it through the holes provided for this purpose, and attach it to the box with cable ties, also called tie-wraps.

**Make sure to connect the Left and Right lights to the correct wiring identified Left and Right. **

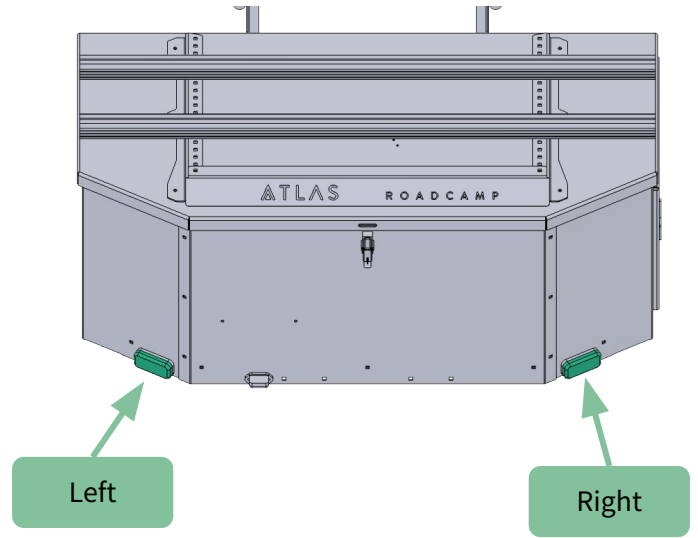

15 SLIDE-OUT SYSTEM ASSEMBLY

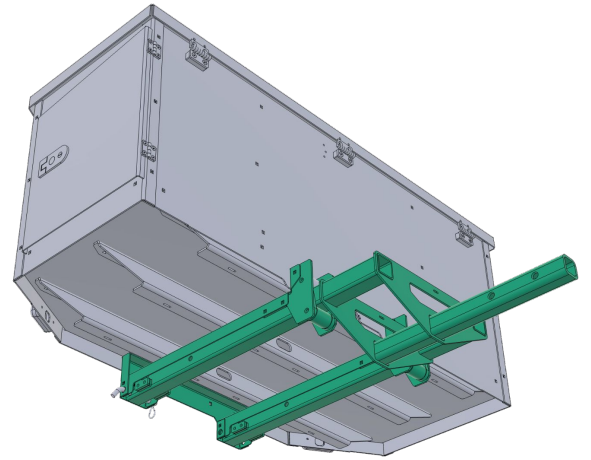

COMPONENT DESCRIPTION

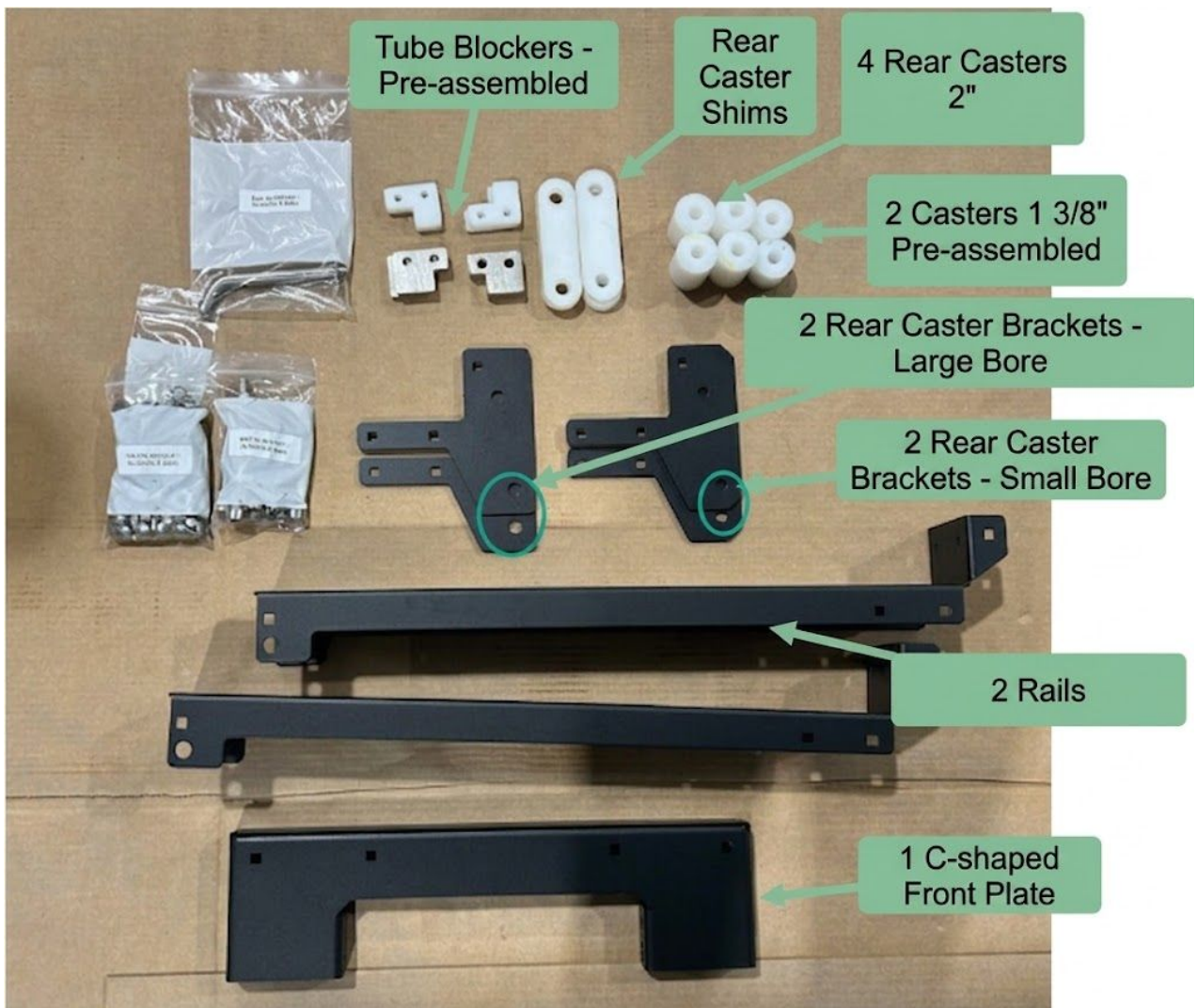

16 INSTALL THE FRONT C-SHAPED PLATE

- Insert the 4 carriage bolts from the outside toward the inside. (A)
- Make sure to place the C-plate inside the box panel.
- Install the washers on the bolts from the inside.
- Apply anti-seize to the bolt threads.
- Tighten the nuts to the specified torque of 24 Nm.

HARDWARE: Bag SLIDE-OUT



4x Carriage bolts 5/16" x 3/4"



4x Washers 5/16"



4x Nylon lock nuts 5/16"

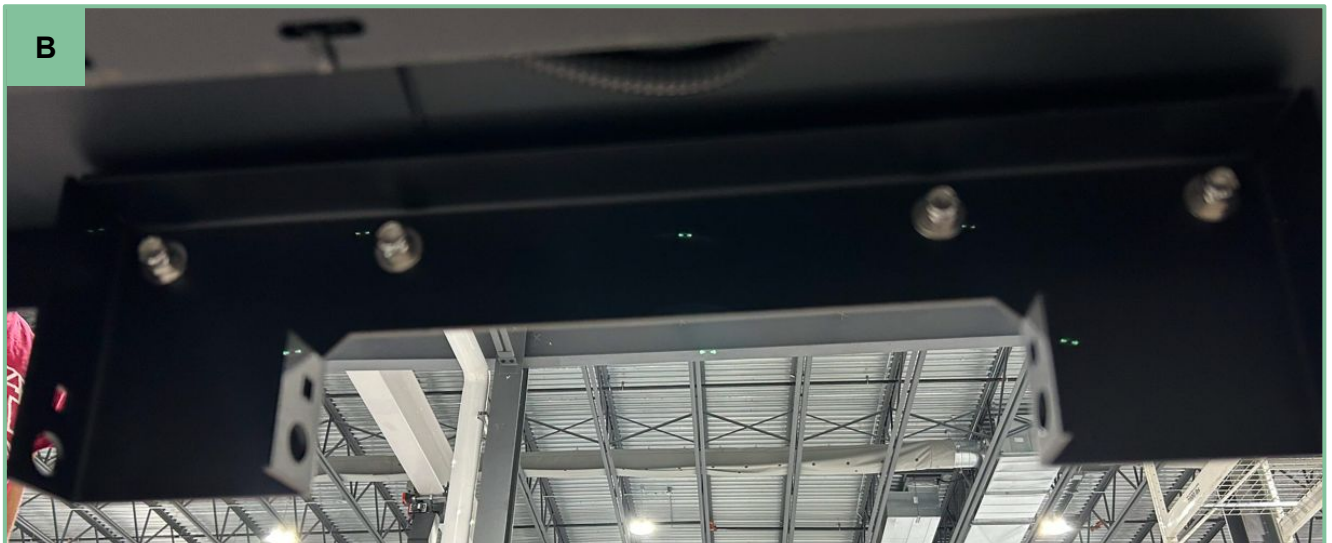
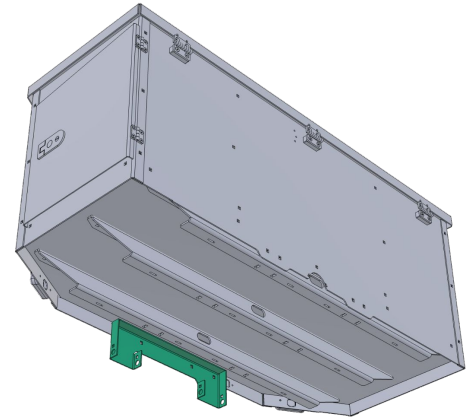

17 INSTALL THE FIXED RAILS

17.1 Install the lower bolts.

- Insert the fixed rails into the C-plate and hold them to the box with clamps.
- Insert the 5/16" × 3/4" bolts into the rail holes to attach them to the stiffeners.
- Install the washers onto the bolts.
- Apply anti-seize to the bolt threads.
- Tighten the nuts to the specified torque of 24 Nm.

HARDWARE: Bag SLIDE-OUT



12x Carriage bolts
5/16" x 3/4"



12x Washers 5/16"



12x Nylon lock
nuts 5/16"

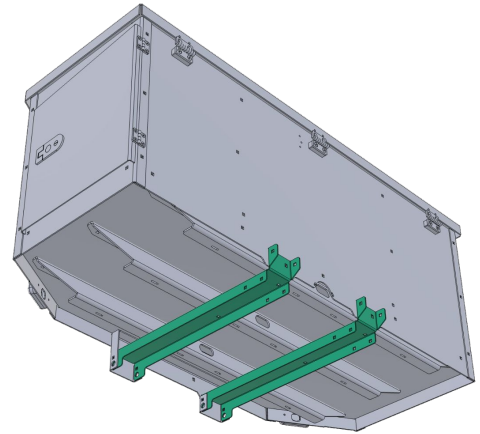

Example of tightening with clamps

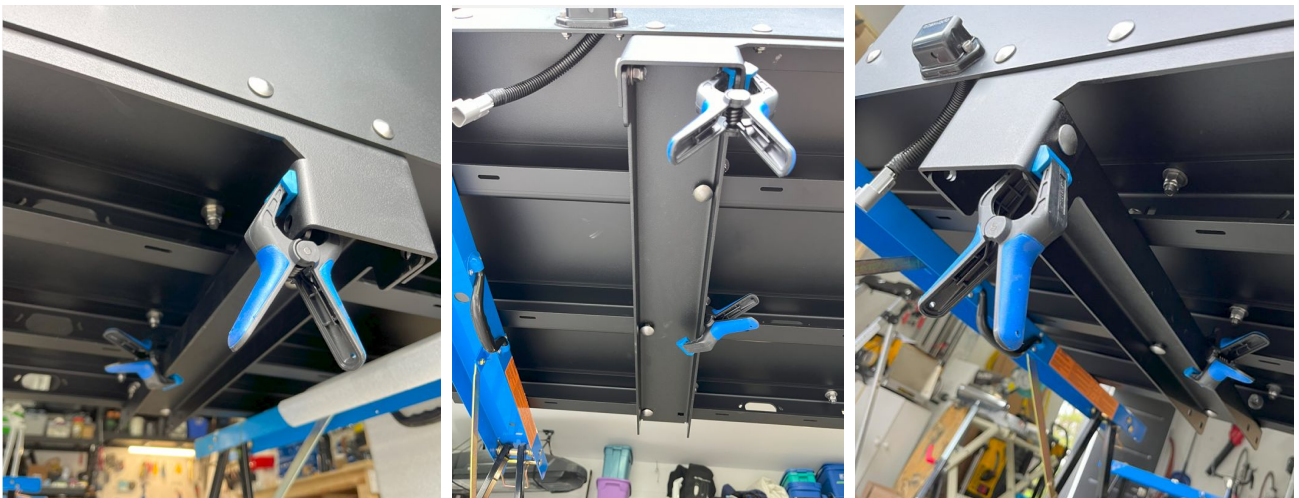

17 INSTALL THE FIXED RAILS

17.2 Install the rear bolts.

- Insert the 5/16" × 1" bolts into the rail holes to attach them to the rear panel.
- Install the washers onto the bolts.
- Apply anti-seize to the bolt threads.
- Tighten the nuts to the specified torque of 24 Nm.

HARDWARE: Bag SLIDE-OUT



4x Carriage bolts 5/16" x 1"



4x Washers 5/16"



4x Nylon lock nuts 5/16"

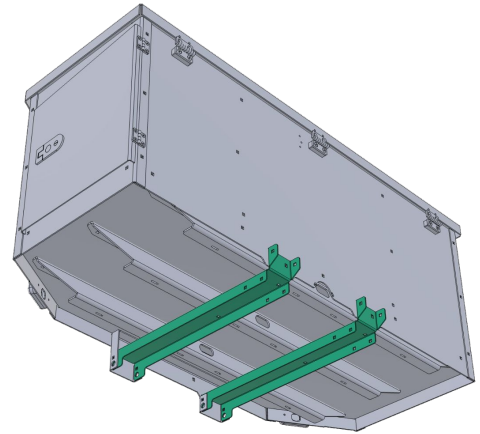

18 INSTALL THE 2" REAR ROLLER RETAINING PLATES

****Be careful: there are 2 plate models — 1 with a large hole and 1 with a small hole ****

They must be paired together: 1 small-hole plate with 1 large-hole plate.

- Insert the 5/16" × 1" bolts into the rail holes to attach them to the rear panel.
- Install the washers onto the bolts.
- Apply anti-seize to the bolt threads.
- Tighten the nuts to the torque specified at the beginning of the guide.

HARDWARE: Bag SLIDE-OUT

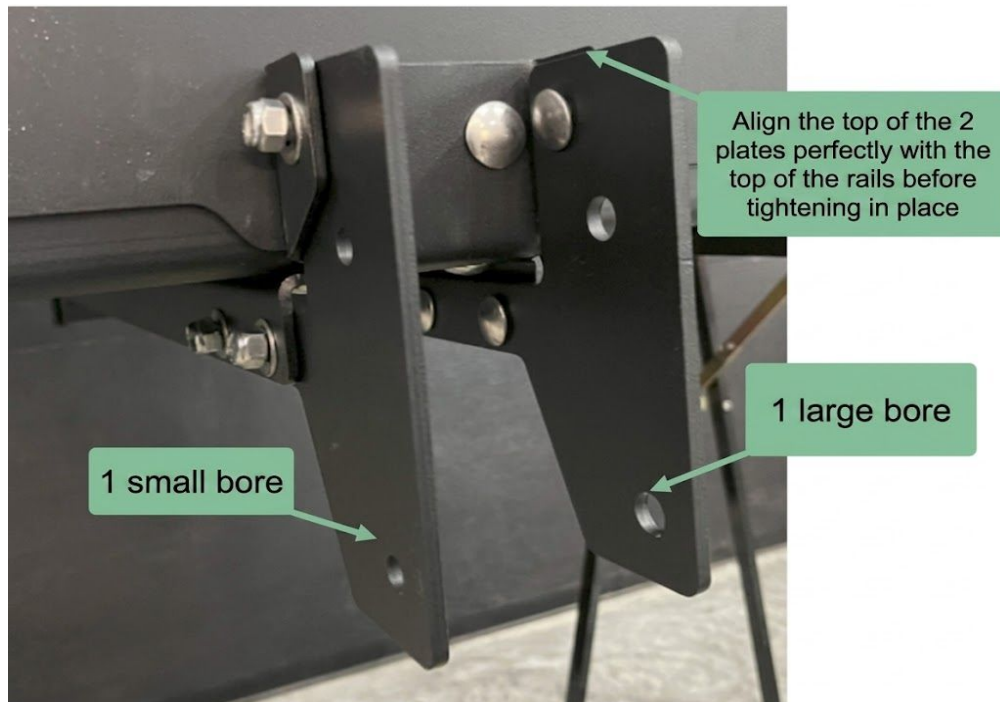
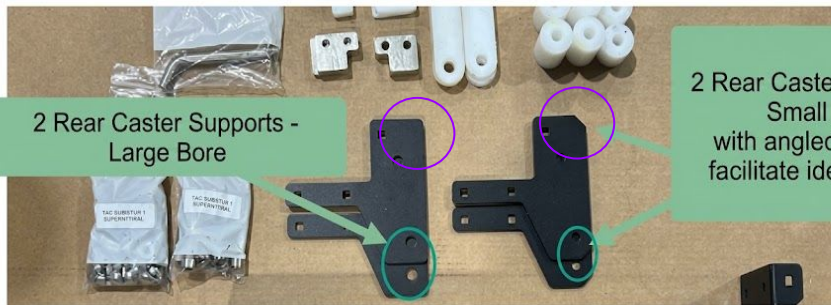
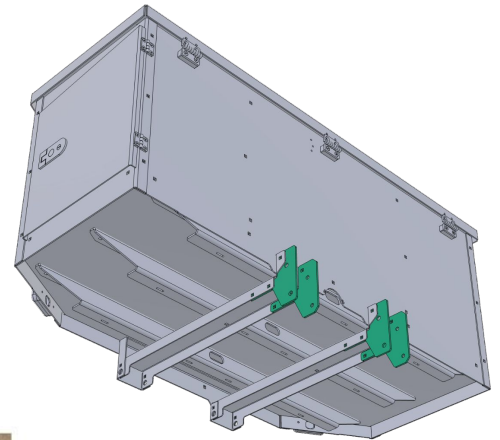

19 INSTALL THE UPPER ROLLERS WITH THE UHMW GUIDE PLATES



A Insert the M12 × M10 × 80 mm shoulder bolts with the first spacer.

B Add the 2" roller onto the bolt.

C Insert the other spacer inside the support plate.

D Install the nut on the outside of the support plate. Do not overtighten for now.

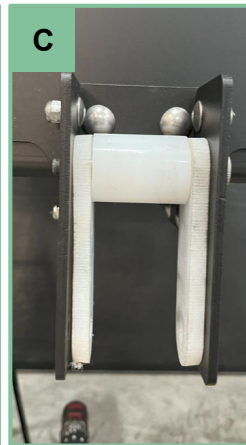
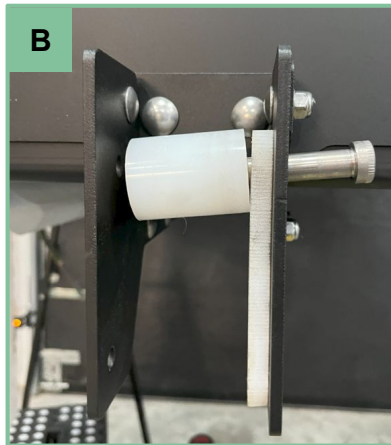
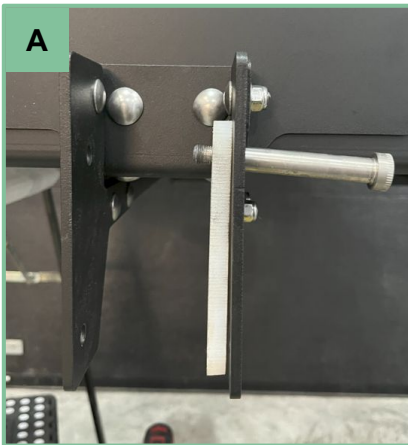
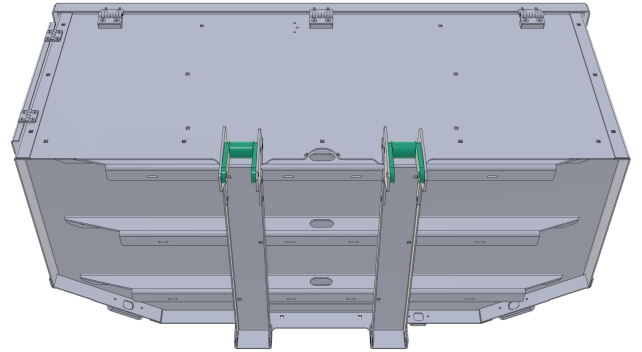

20 INSTALL THE FIXED Y-TUBE

Identification of the Y hitch tube

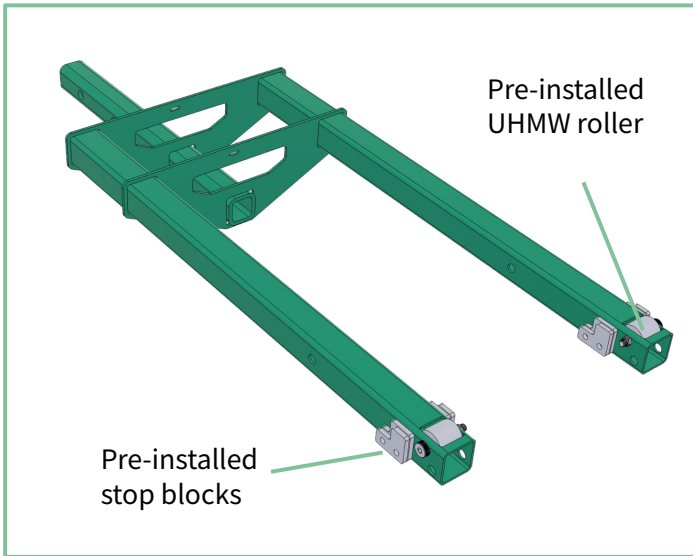

HARDWARE: Bag SLIDE-OUT



1x Safety rod

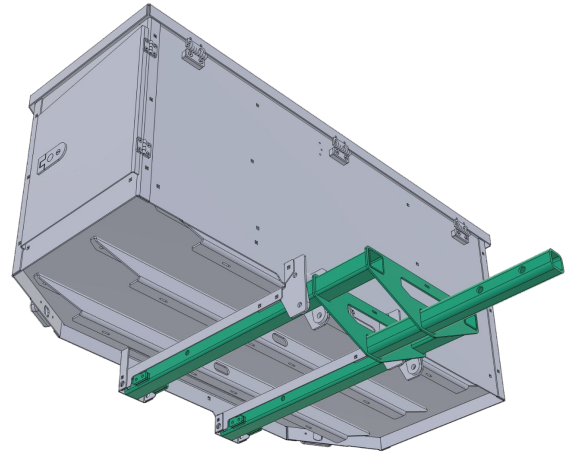

****This step requires 2 people. ****

- Take the steel Y-tube, place it under the box, and install the retaining pin.



21 INSTALL THE LOWER ROLLERS

HARDWARE: Bag SLIDE-OUT

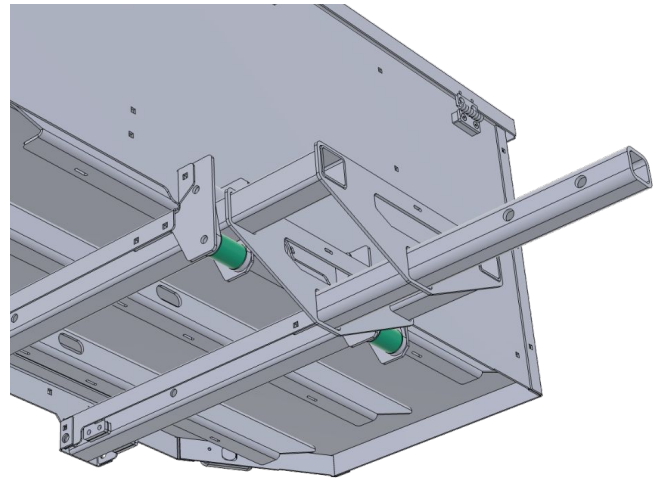
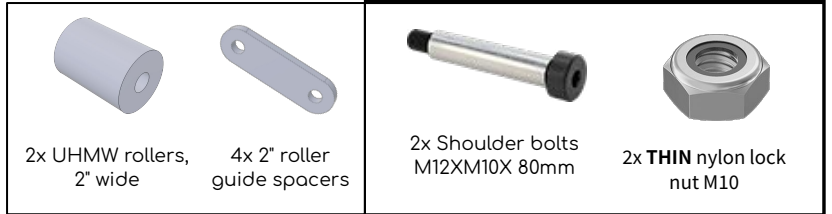

** This step requires 2 people. **

- Install the lower rollers exactly the same way as the upper rollers in Step 17.

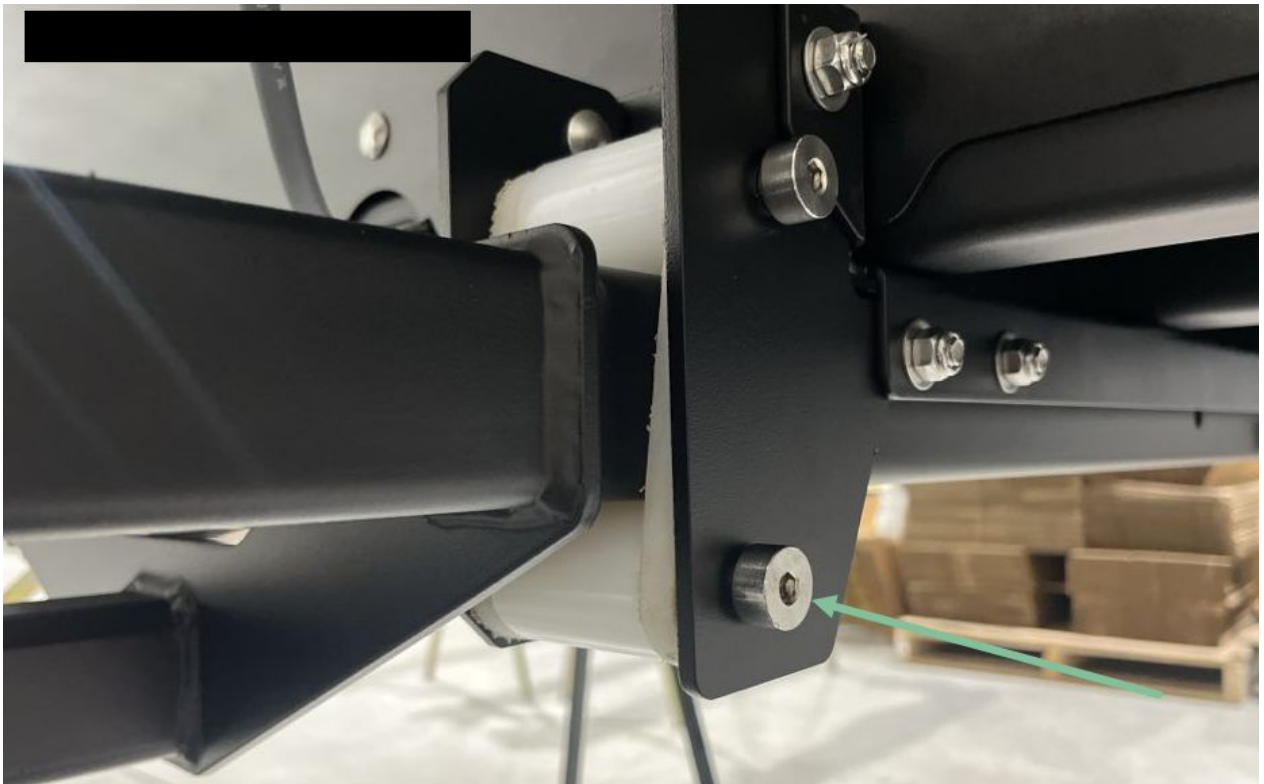

22 ATTACH THE ELECTRICAL WIRE FOR THE LIGHTS TO THE Y-TUBE WITH A TIE WRAP

**** Make sure to leave enough slack to allow maximum travel of the slide-out system. ****



23 INSTALL THE BOX ONTO THE VEHICLE HITCH.

23.1 Simply slide the 2" × 2" tube into the hitch and insert the 5/8" lock.



Hitch lock 5/8"

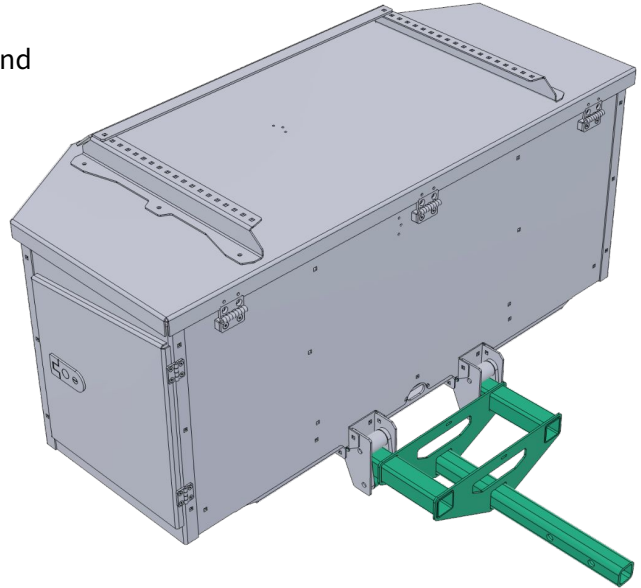

23.2 Install the stabilization system — hitch clamp

****It is important to tighten the nuts and locknuts.****



BIKE RACK OPTION, PURCHASED SEPARATELY

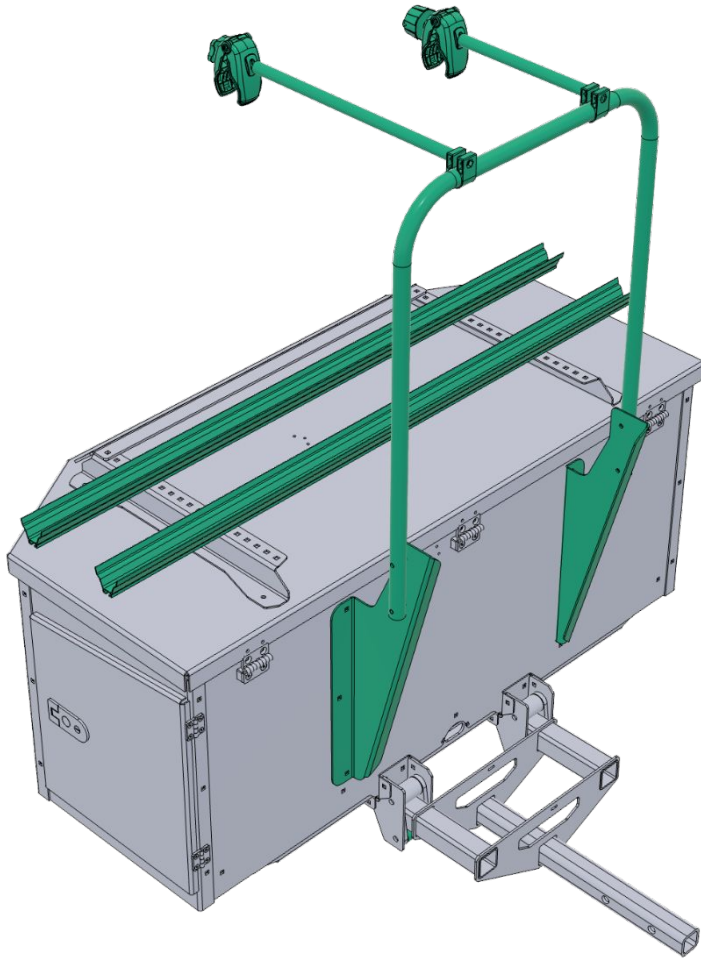

24 INSTALL THE 2 TRANSITION PLATES FROM THE CARGO BOX TO THE RACK

****Note:** there is a left plate and a right plate. The hoop is located on the outside of the plates. ******

- Insert the 6 bolts from the outside toward the inside. (A)
- Install the Washer on the bolts from the inside.
- Apply anti-seize to the bolt threads.
- Tighten to 30 Nm.

HARDWARE: Bag #2



6x Carriage bolts 5/16" x 3/4"



6x Washer 5/16"



6x Nylon lock nuts 5/16"

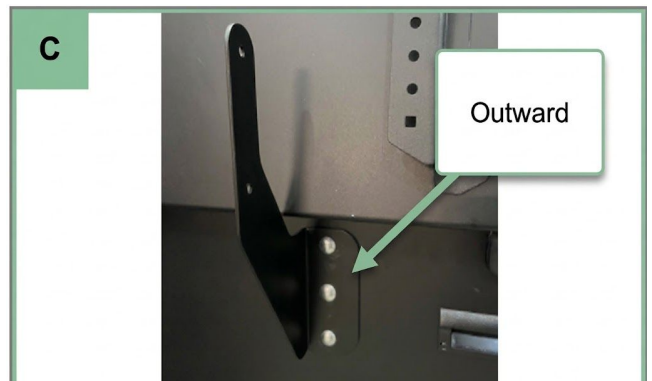
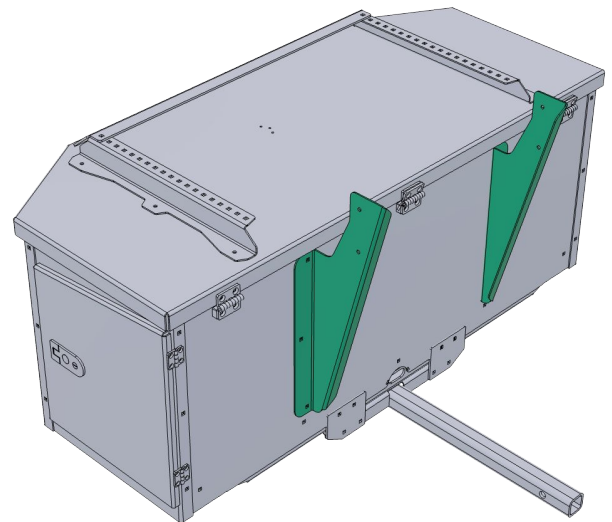

25 INSTALL THE ARVIKA HOOP

- Insert the 4 bolts from the outside toward the inside.
- Install the washers on the bolts from the inside.
- Apply anti-seize to the bolt threads.
- Tighten the nuts to 24 Nm.



HARDWARE: Bag #5



4x Hex bolts 5/16" x 1 3/4"



4x Washer 5/16"



4x Nylon lock nuts 5/16"

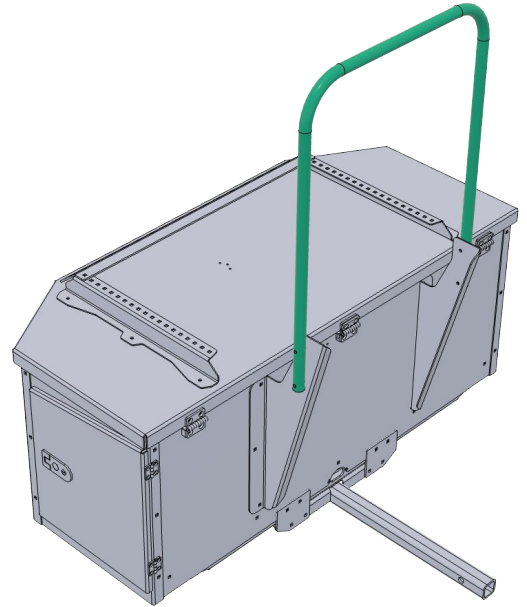

26 INSTALL THE ARVIKA STABILIZER ARMS

- Disassemble the stabilizer arm assembly using the main handle.
- Slide the clamp collar onto the rear hoop.
- Reassemble the assembly.

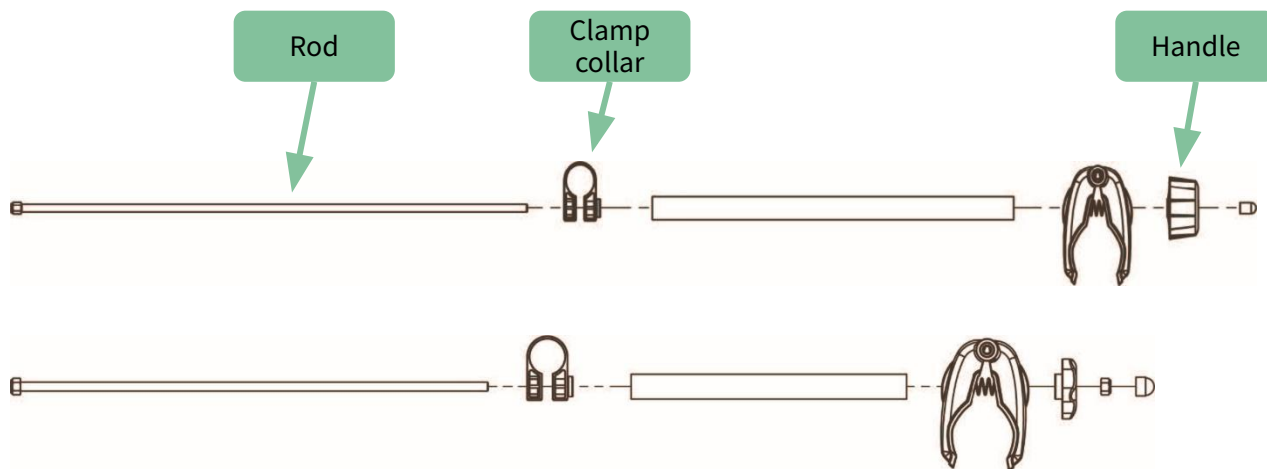
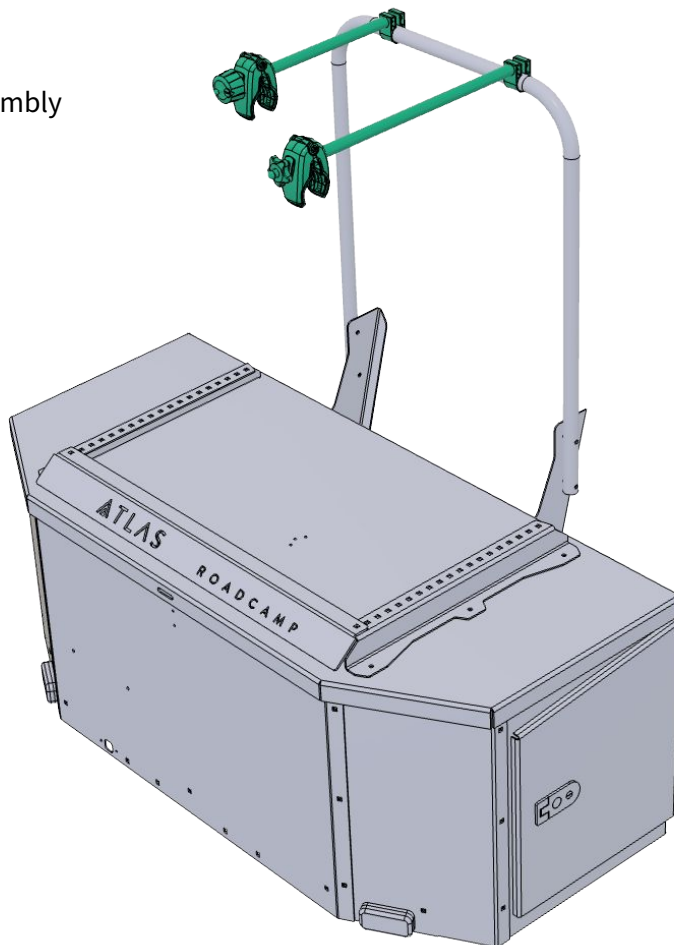

27 INSTALL THE GUTTERS ONTO THE Z-ATLAS

27.1 Insert 2 bolts into the keyway of each rail.



27.2 Slide the wheel stoppers onto the gutters. Either direction is acceptable; you can confirm the orientation when you install your bikes on the gutters.

- Install one washer and one star knob on each wheel support.



HARDWARE: Bag #2



4x Carriage bolts 5/16" x 3/4"



4x Washer 5/16"



4x Nylon lock nuts 5/16"

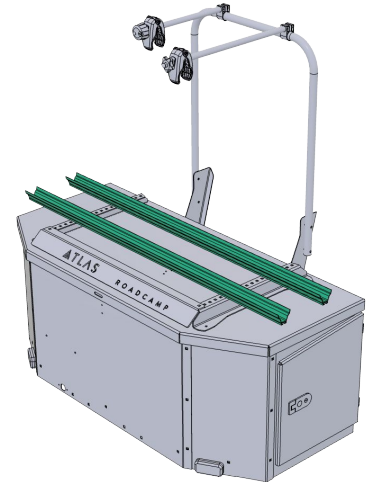

27.3 Align the gutters according to the distance of the stabilizer arms. Confirm the gutter location using your bike.



27 INSTALL THE GUTTERS ONTO THE Z-ATLAS

27.4 Tighten the gutters with the nuts, inserting one washer. Make sure the gutters are centered with the box.



HARDWARE: Bag #2



4x Carriage bolts 5/16" x 3/4"



4x Washer 5/16"



4x Nylon lock nuts 5/16"

27.5 Confirm the position of the wheel stoppers according to the width of your bike and tighten the star knobs under the stoppers.



27.6 Install the plastic end caps on each end of the gutters.

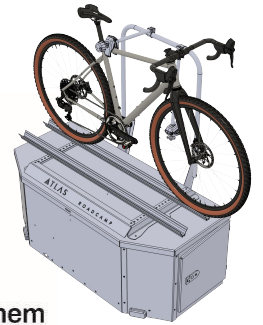

28 SECURE THE BIKES
**OPERATING THE BIKE RACK
FONCTIONNEMENT DU SUPPORT À VÉLOS**

ARMS / BRAS

After securely placing your bikes within the designated gutters, the next step is to affix them to one of the support arms. You have the flexibility to fasten them using either the bike's frame (see figure A), the bench (see figure B), or even the front of your bicycle (see figure C), ensuring a secure and reliable attachment.

Après avoir placé vos vélos dans les gouttières prévues à cet effet, l'étape suivante consiste à les fixer à l'un des bras de support. Vous avez la possibilité de les fixer en utilisant le cadre du vélo (voir figure A), le banc (voir figure B) ou même l'avant du vélo (voir figure C), ce qui garantit une fixation sûre et fiable.

WHEEL STOPPER / CALES DE ROUE

After securely placing your bikes within the designated gutters, the next step is to affix them to one of the support arms. You have the flexibility to fasten them using either the bike's frame (see figure A), the bench (see figure B), or even the front of your bicycle (see figure C), ensuring a secure and reliable attachment.

Après avoir placé vos vélos dans les gouttières prévues à cet effet, l'étape suivante consiste à les fixer à l'un des bras de support. Vous avez la possibilité de les fixer en utilisant le cadre du vélo (voir figure A), le banc (voir figure B) ou même l'avant du vélo (voir figure C), ce qui garantit une fixation sûre et fiable.



QUESTION?

If you need assistance or have any questions during installation, please contact us. We will be happy to assist you.

TEL: (819) 582-2612
INFO@ATLASROADCAMP.COM
4615, BOUL. DE PORTLAND, SHERBROOKE

ATLAS
ROADCAMP

